

SIMULATION AND EXPERIMENTAL TESTING OF THE STRAW TRACKER PROTOTYPES FOR THE SPD EXPERIMENT

S. Bulanova¹, V. Bautin², A. Chukanov², T. Enik², A. Gurova³,
V. Kim¹, N. Korotkova⁴, E. Kuznetsova^{1,5}, A. Lapkin², A. Lazarev¹,
A. Nartov¹, S. Romakhov^{2,5}, D. Sosnov¹
¹NRC Kurchatov Institute – PNPI, ²Joint Institute for Nuclear Research, Dubna, ³National Research Nuclear University MEPhI, ⁴Skobeltsyn Institute of Nuclear Physics of the Moscow State University, ⁵Institute of Nuclear Physics, Almaty, Kazakhstan

ABSTRACT

The Straw Tracker of the future SPD experiment at the NICA collider is designed for both track coordinates and momentum of charged particles measurements and identifying low-momentum particles (Particle Identification, or PID). The coordinate measurements require fast readout electronics response in order to reduce threshold crossing time fluctuations. For Particle Identification, the average values of ionization losses are used, which is determined by the induced charge. To achieve the required accuracy for both coordinate and energy loss measurements, optimization of the readout electronics parameters is necessary. To determine the requirements for the Straw tracker electronics and to select its optimal parameters, simulation of detector response and experimental measurements with tracker prototypes and readout electronics are used. The report is dedicated to the measurements of ionization losses in a single straw tube prototype. The results of measurements on proton, electron, and pion beams are compared with the results of simulating the straw tube response with the Garfield++ and LTspice software packages.

CHARGE RESOLUTION AS A FUNCTION OF THE CHARGE INTEGRATION TIME

The principle of Particle Identification, or PID, for low momentum particles with the Straw Tracker is based on the measurement of ionization energy losses dE/dx . As a charged particle crosses the detector volume, it ionizes the working gas, and primary ionization electrons are released along particle's trajectory. Primary electrons drift to the anode wire where charge multiplication occurs. The Straw signal is measured with readout electronics corresponds to the charge induced on the straw electrodes during the peaking time. Since the peaking time is usually significantly smaller than the total electron and ion drift time, only part of total charge is measured. This introduces additional fluctuation of the measured ionization energy loss. The ionization energy losses have Landau distribution, which is characterized with the Most Probable Value, MPV, and the distribution width, Sigma. Dependence of the relative distribution width Sigma / MPV of the induced charge distribution on the charge integration time is shown in Fig. 1 these results are obtained using Garfield++ simulation for a single straw for electrons and pions with the momentum of 2 GeV/c.

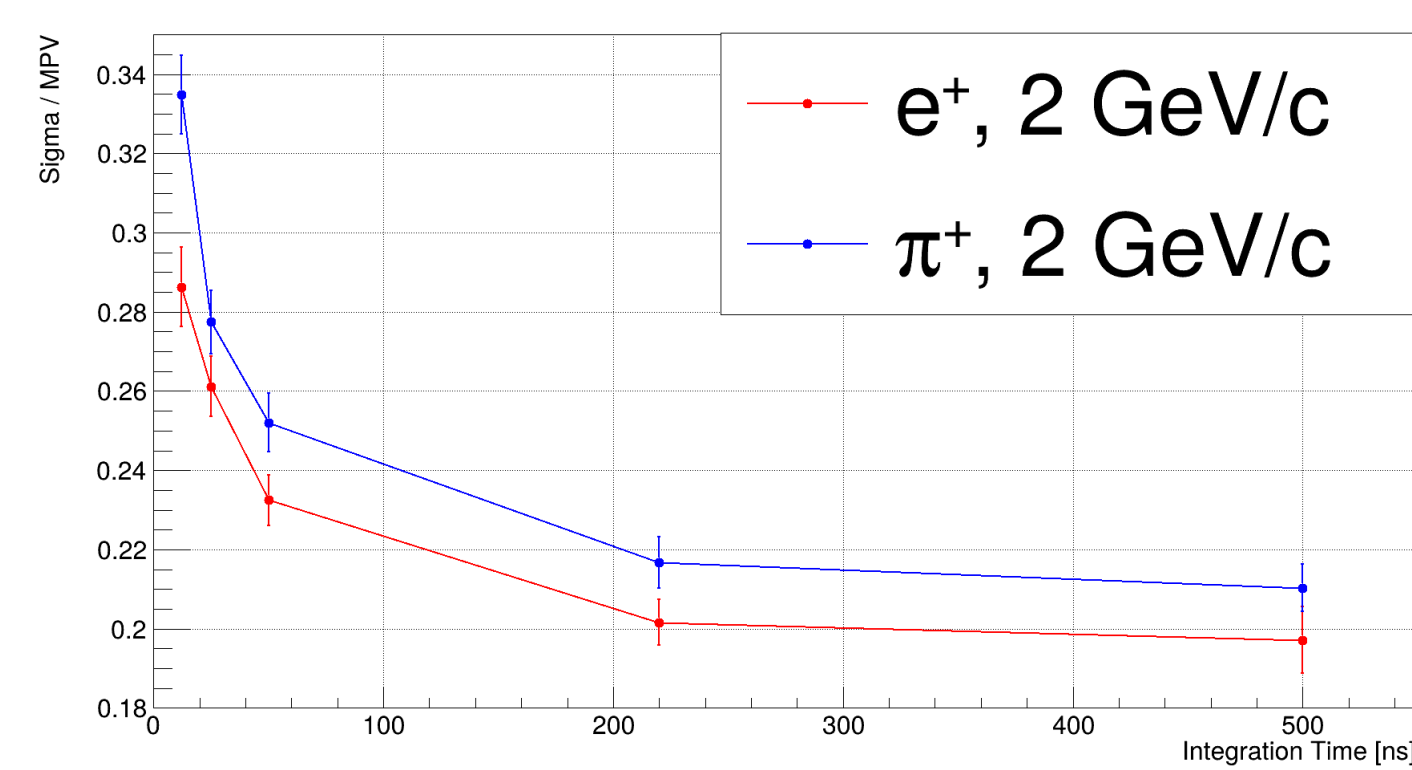

Figure 1: Charge resolution as a function of the integration time.

THE TEST BEAM SETUP

Straw charge resolution measurements were performed with test beams at PS (CERN) and SC-1000 (PNPI, Gatchina) proton accelerators. The test beam data obtained at PNPI also serve for testing the required dynamic range for PID of low momenta protons. At the PS a secondary hadron beam consisting of 2 GeV/c pions and e+, was used for the measurements. A pure positron beam was used for cross-check. For positron ID a Cherenkov detector available at the beam line was used. General layout of the experimental setup is shown in the Fig. 2. To normalize the value of signal per unit length, it is needed to know the distance between an anode wire and a particle track. For reference coordinate determination, six planes of the precise Azalea silicon tracker are used. Straw signal digitization was performed with a CAEN digitizer with custom preamplifier with peaking time equal to 220 ns and gain 1 mV/fC.

THE TEST BEAM SETUP (CONTINUE)

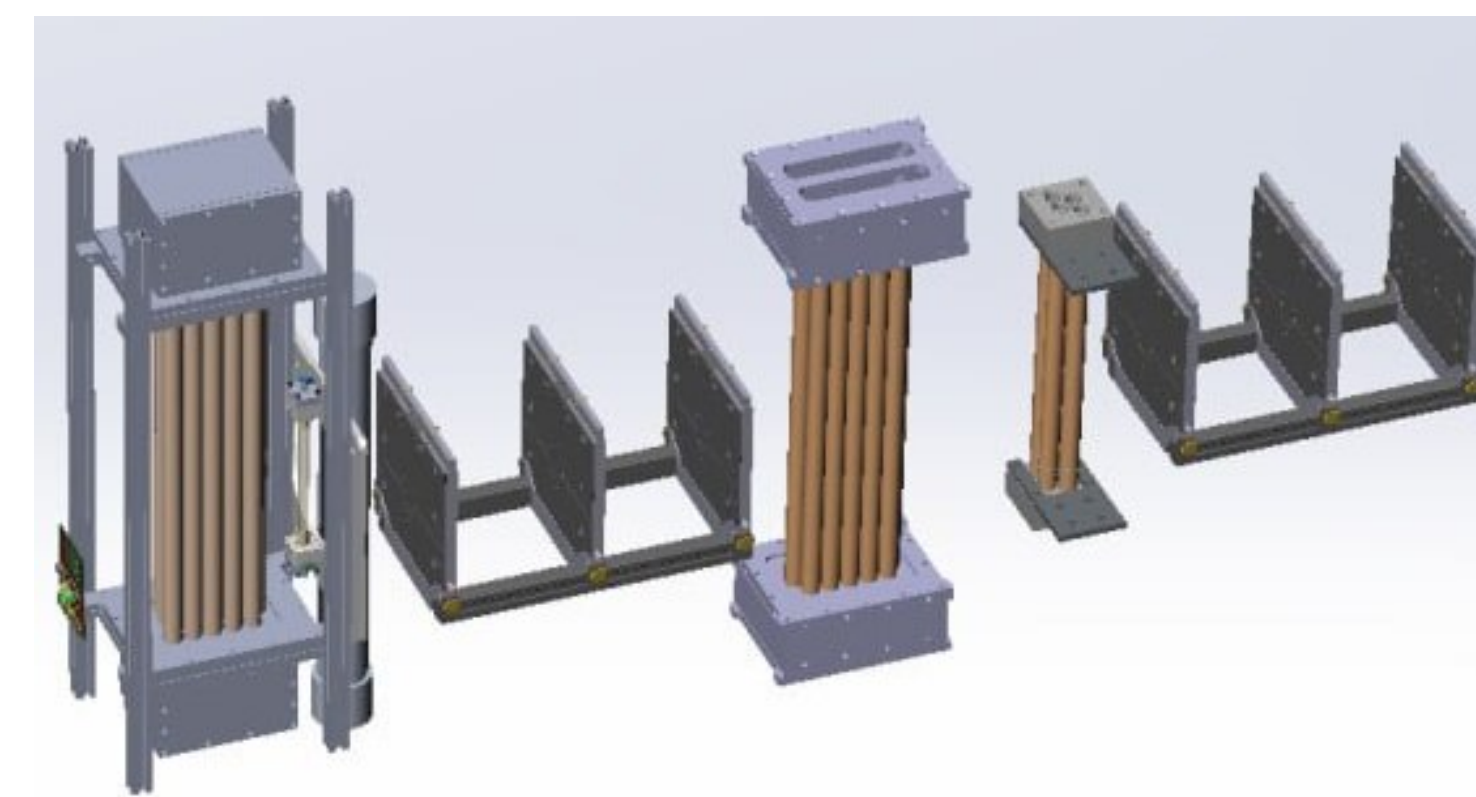

Figure 2: Test Beam setup with a single straw.

In the Fig. 3 is shown available momenta range at PS and SC-1000 relatively to performance for particle identification with dE in the straw tube.

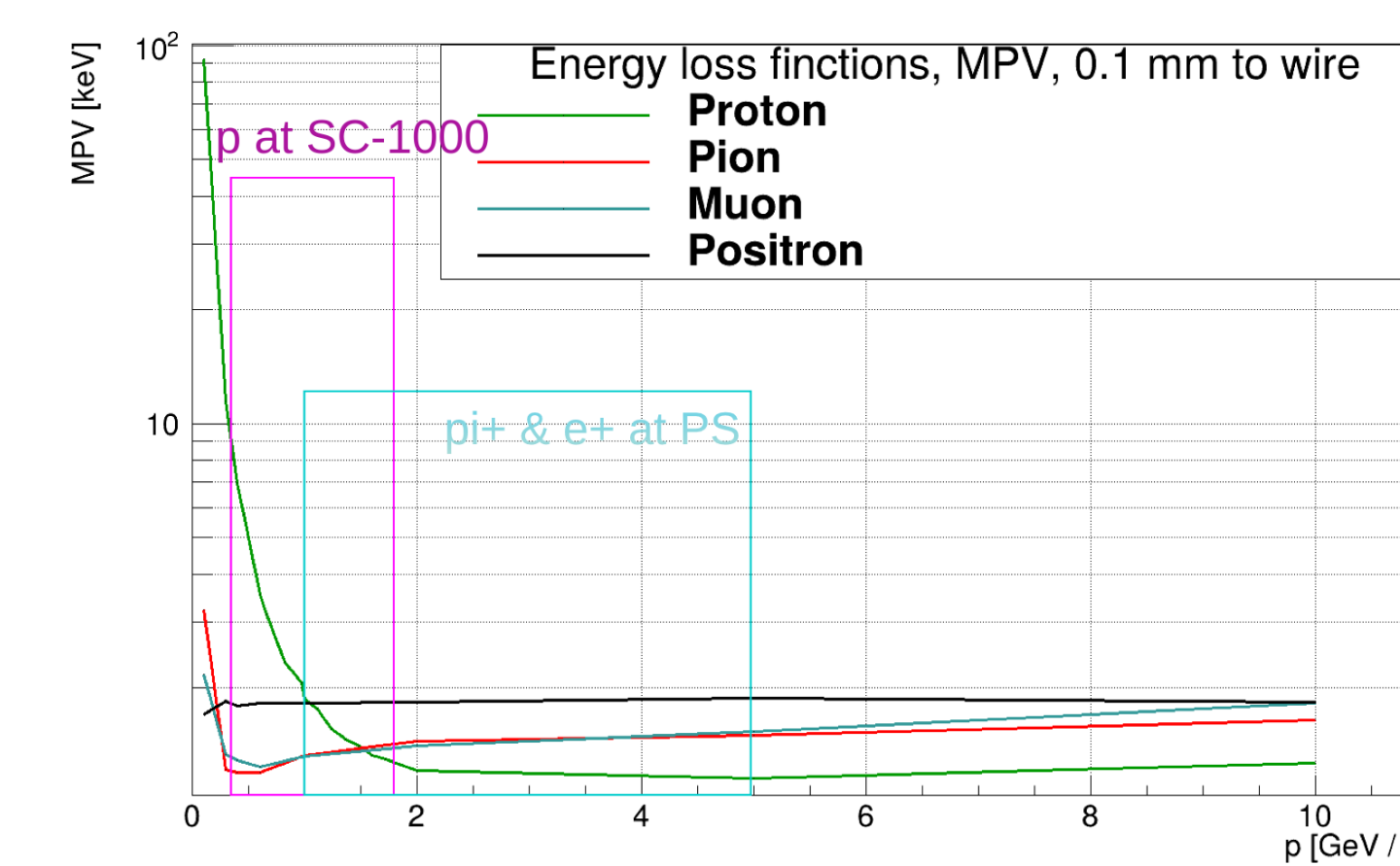

Figure 3: The ionization energy loss MPV fits for different particle types as functions of the particle momentum relatively to momenta range at PS (cyan) and SC-1000 (magenta).

CHERENKOV TAG FAKE RATE ESTIMATION

The efficiency of the Cherenkov tag is calculated using a reference positron beam. The efficiency is found to be 97%. Fig. 4(b) compares the charge distribution measured for positrons of the hadron beam which are tagged with the Cherenkov detector, for the positron beam and the charge distribution obtained in simulation studies.

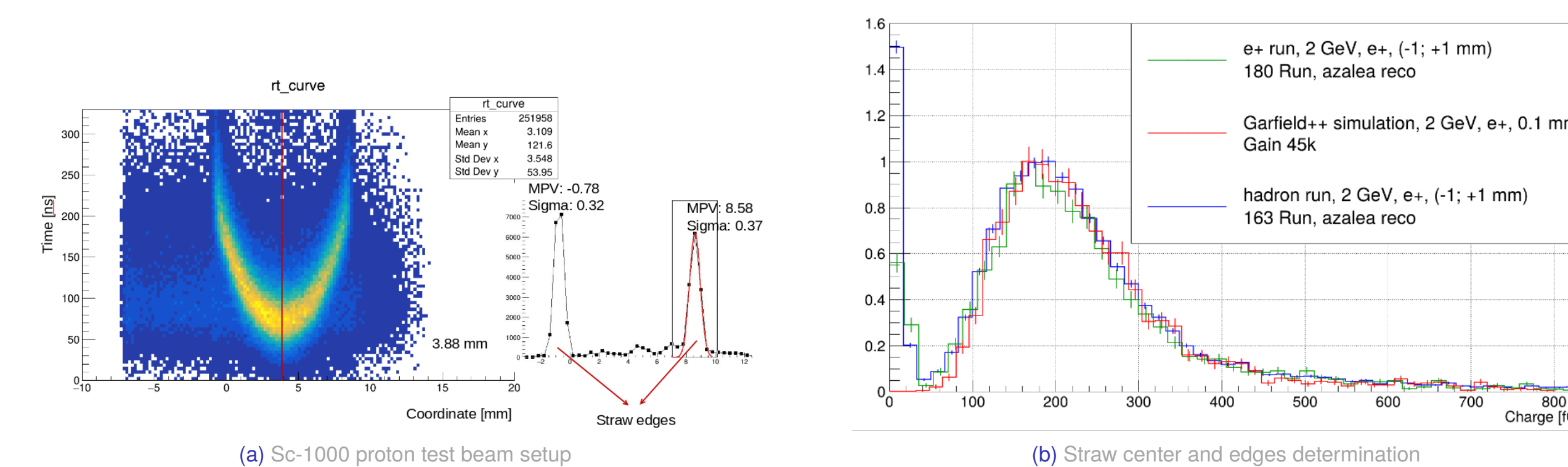

Figure 4: Charge distributions of reference positrons and positrons from the hadron beam obtained with measurements and simulation studies.

The charge distributions of positrons from the pure positron beam and from the hadron beam are in a good agreement and prove the low fake rate of the Cherenkov tag.

ANALYSIS RESULTS COMPARED TO MONTE CARLO SIMULATION

Since the distance between the track and the wire is known from a two-dimensional distance–amplitude dependence Fig. 4(b), this allow us to normalize the measured charge to the track length as it is shown in the Fig. 5. The data obtained with positrons and hadrons are compared to the simulation study results.

ANALYSIS RESULTS COMPARED TO MONTE CARLO SIMULATION (CONTINUE)

Table 1 shows fit results. Data are in a good agreement with simulation.

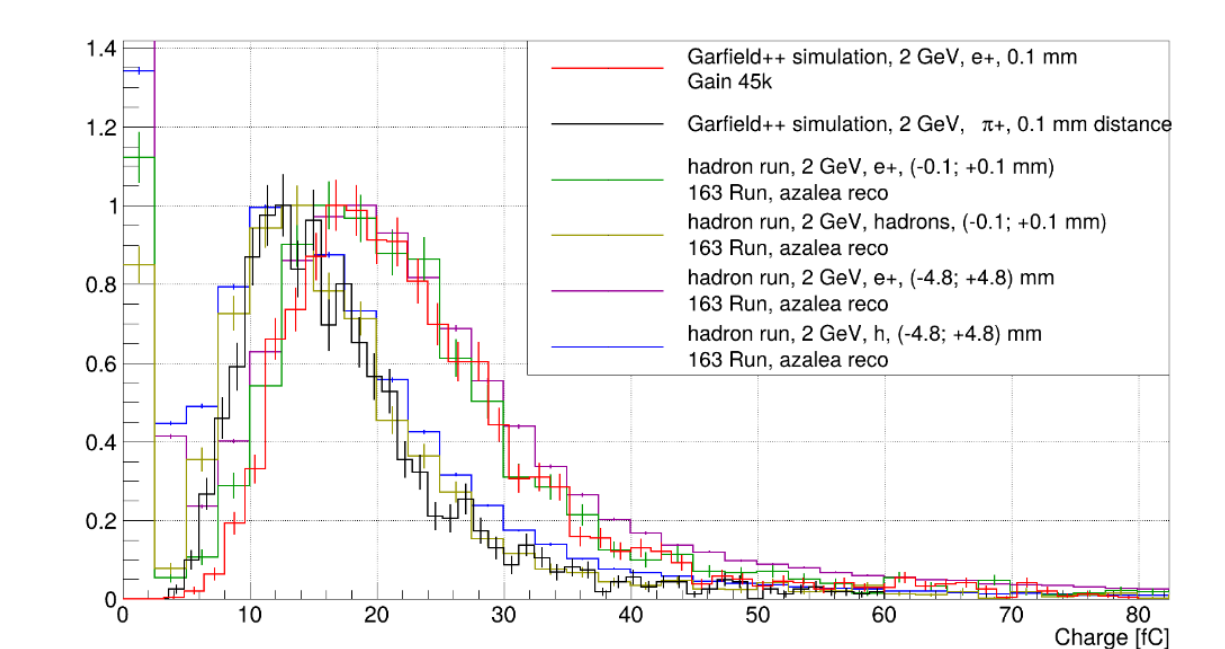

Figure 5: Charge distributions obtained with measurements and Garfield++ simulation studies for positrons and hadrons.

	MPV	σ	σ/MPV
Garfield++, e+	17.7	3.8	0.21
Data, e+	18.4	4.11	0.22
Garfield++, π^+	12.6	2.93	0.23
Data, π^+	12.8	3.10	0.24

Table 1: Simulation and test beam data fit results for e+ and π^+ .

PROTON BEAM DATA COMPARED TO MONTE CARLO SIMULATION

The setup at PNPI was similar to the setup at the PS, as it is shown in the Fig. 6(a), the only difference being that a Micromegas detector was used as the reference tracker, while a multiwire proportional chamber (MWPC) was used for precise tracking. SC-1000 beam consists of protons with less momenta range from 0.4 GeV/c to 1.6 GeV/c.

A momentum scan was performed at the test beam at SC-1000. Reference tracking was performed using a single plane Micromegas detector. Proton 1.6 GeV/c data shown in the Fig. 6(b) are in a good agreement with simulation.

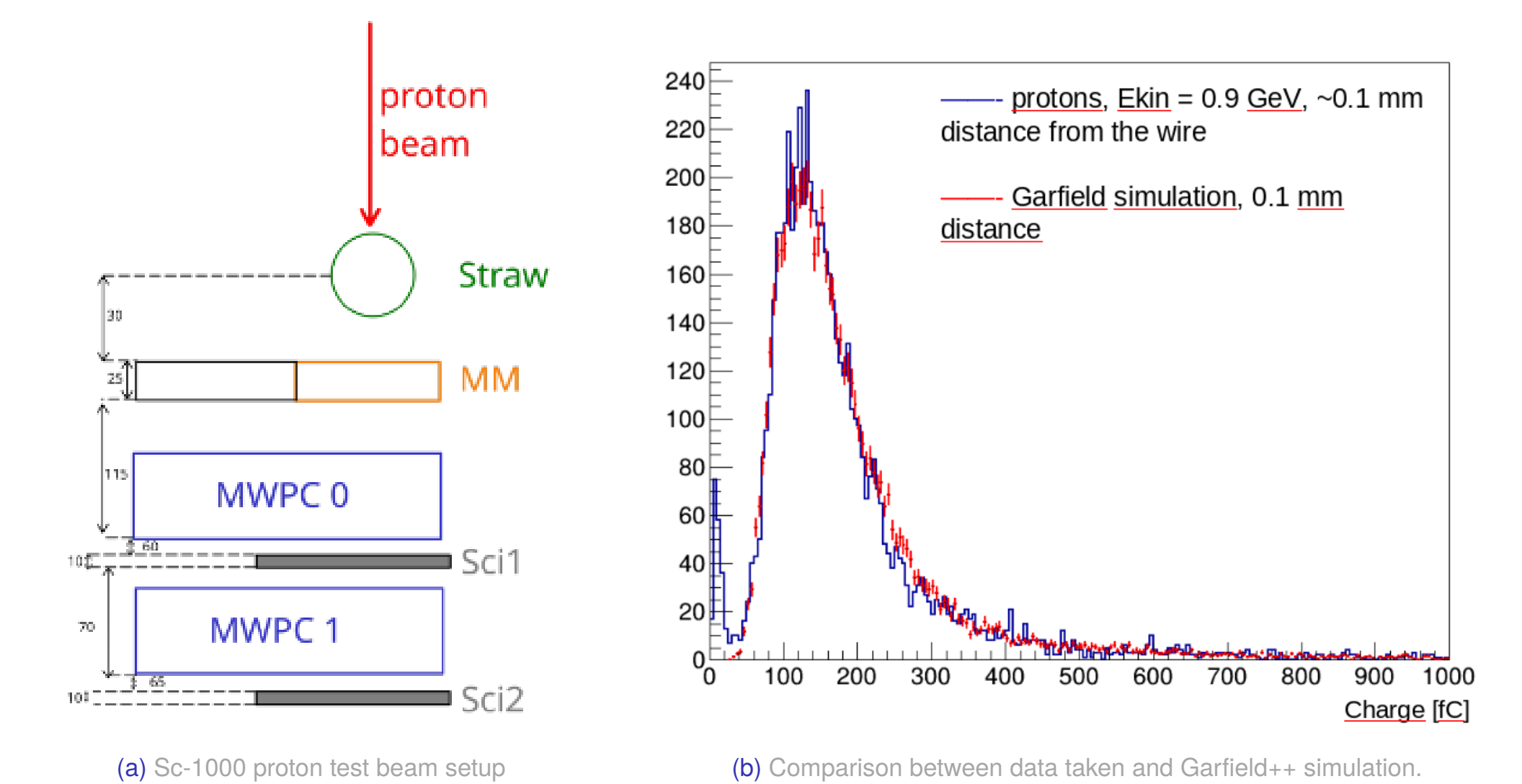

Figure 6: Simulation and test beam data fit results for SC-1000 proton beam.

CONCLUSION

1. Measurements of ionization energy losses in straw tubes are done with the PS and PNPI Test Beams of electrons, pions and protons using a custom readout with large peaking time;
2. Test Beam data acquired with a single straw and the custom readout are in a good agreement with Garfield++ simulation;
3. Analysis of the proton data is ongoing for different proton momenta.