

Chemezov D. D., Khabarov S. V., Kopylov Y. A., Osokin I. S., Sheremeteva A. I., Streletskaia E. A., Tarasov O. G., Zamiatin N. I., Zubarev E. V.
Joint Institute for Nuclear Research

Introduction

BM@N¹ (Baryonic Matter at Nuclotron) is the first experiment of the Nuclotron/NICA ion-accelerating complex studying collisions of relativistic heavy ions with fixed targets in the energy range 1–6 AGeV. The Silicon Beam Tracker (SiBT) subsystem based on double-sided silicon strip detectors (DSSD) provides precise beam monitoring, measures ion trajectories event by event, determines the primary interaction vertex and the beam projectile impact angle. Installed directly in the forward beam of relativistic heavy ions, the SiBT delivers the required tracking accuracy under high radiation load.

Silicon Beam Tracker design

Detector design and geometry:

- **DSSD:** High-resistivity n-type Float Zone silicon; **175 μm thickness** minimizes material budget, reducing radiation-induced noise;
- **Granularity:** active area 61 × 61 mm²; **128 strips/side**, **pitch 470 μm**, orthogonal p+/n+ orientation;
- **Alignment:** Stations are rotated azimuthally (**0°, 30°, 60°**); positioning accuracy **±5 μm**.

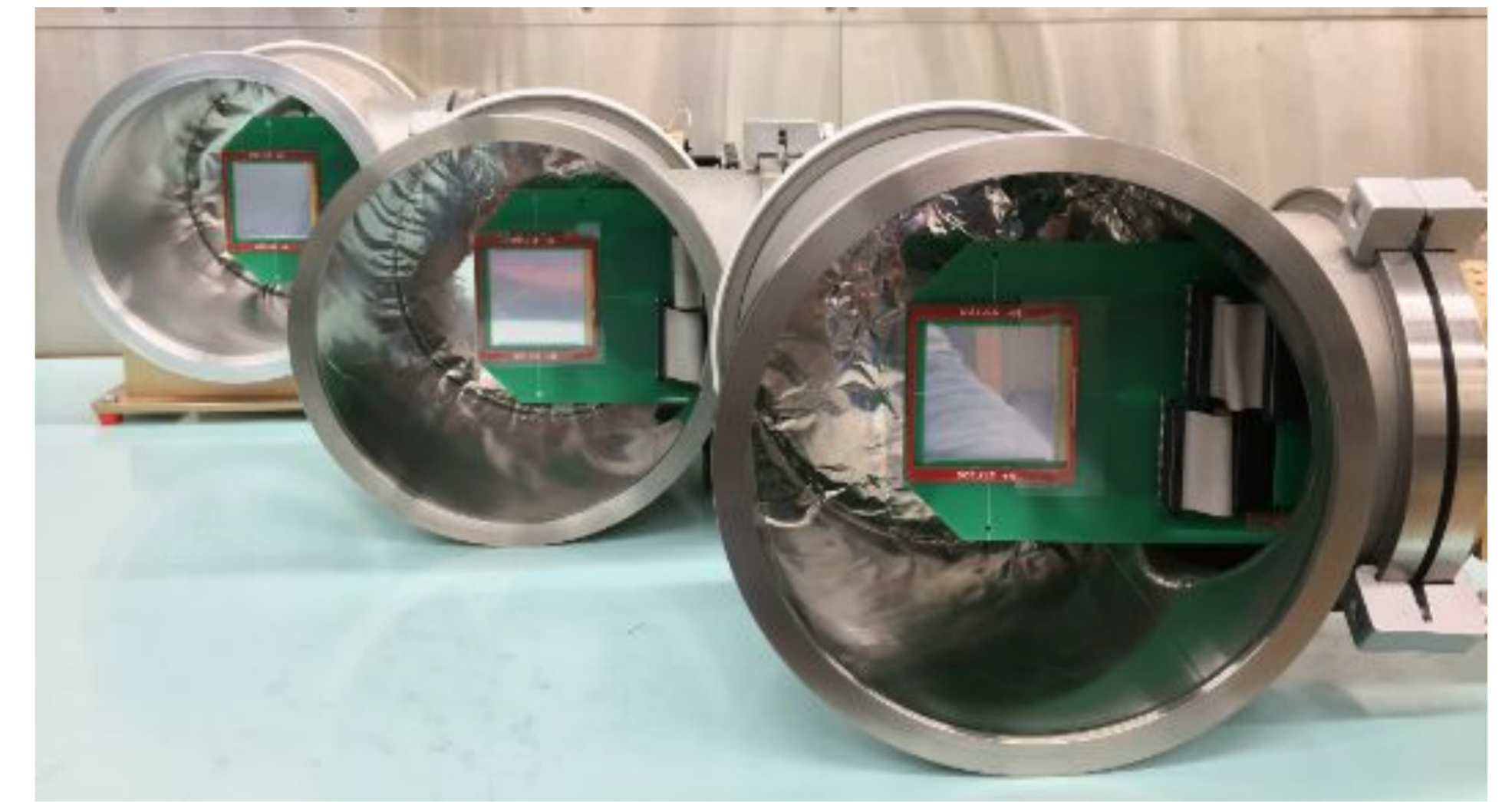
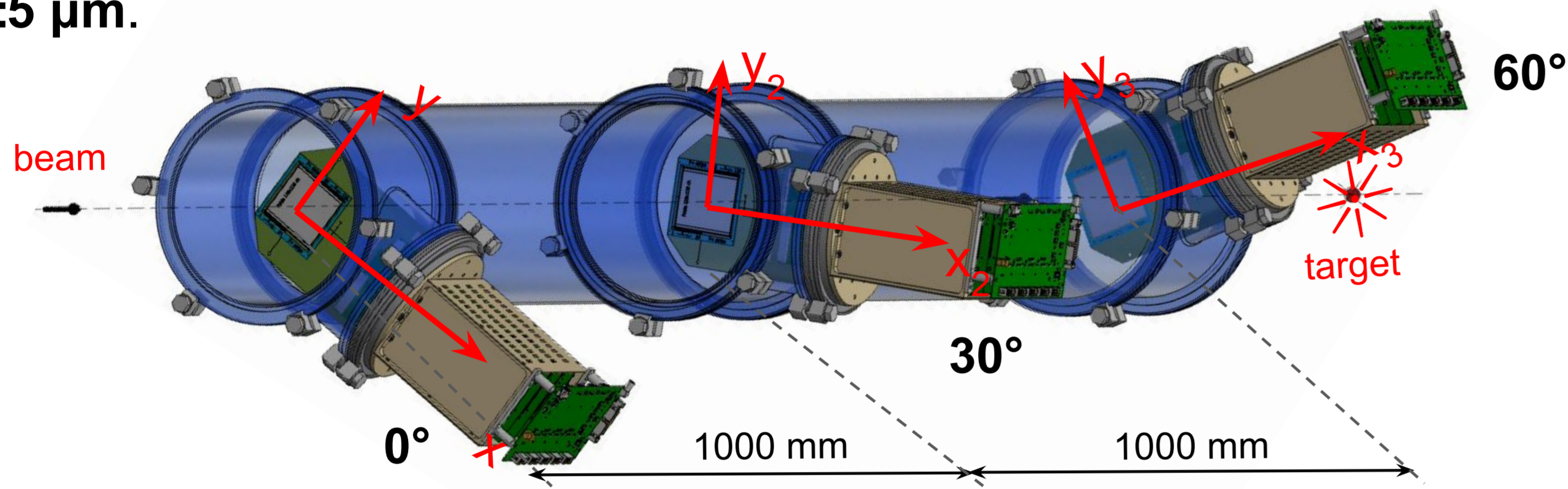

Mechanical Integration & Signal Routing:

- Detectors are mounted on PCBs with ultrasonic Al-wire bonding to gold contact pads;
- Signals are routed via flat cables through vacuum connectors, separating the sensor (in-vacuum) from the readout electronics.

Front-End Electronics (FEE) and Readout:

- **Location:** FEE boards are mounted **outside** the vacuum volume;
- **ASIC:** VATA64HDR16.2 (IDEAS, Norway)². Dynamic Range: –20 to +50 pC (e.g., ~11 pC for 4 AGeV Xe ions); 64 channels (4 ASICs/station);
- **Architecture:** 64-channel parallel shaping and storage, followed by sequential multiplexed readout to a single ADC ch.

BM@N 2026 run

During the run of BM@N 2026 year (run 9) ~2.7 billion events were collected. The SiBT system has operated successfully. Below are beam profiles on SiBT, primary vertices reconstructed by SiBT.

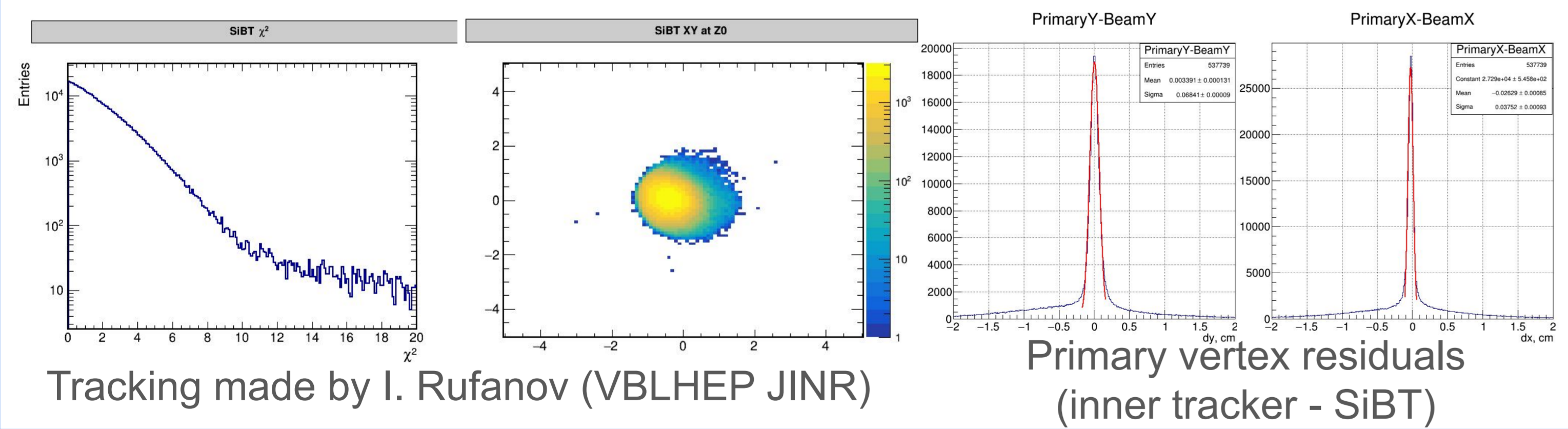
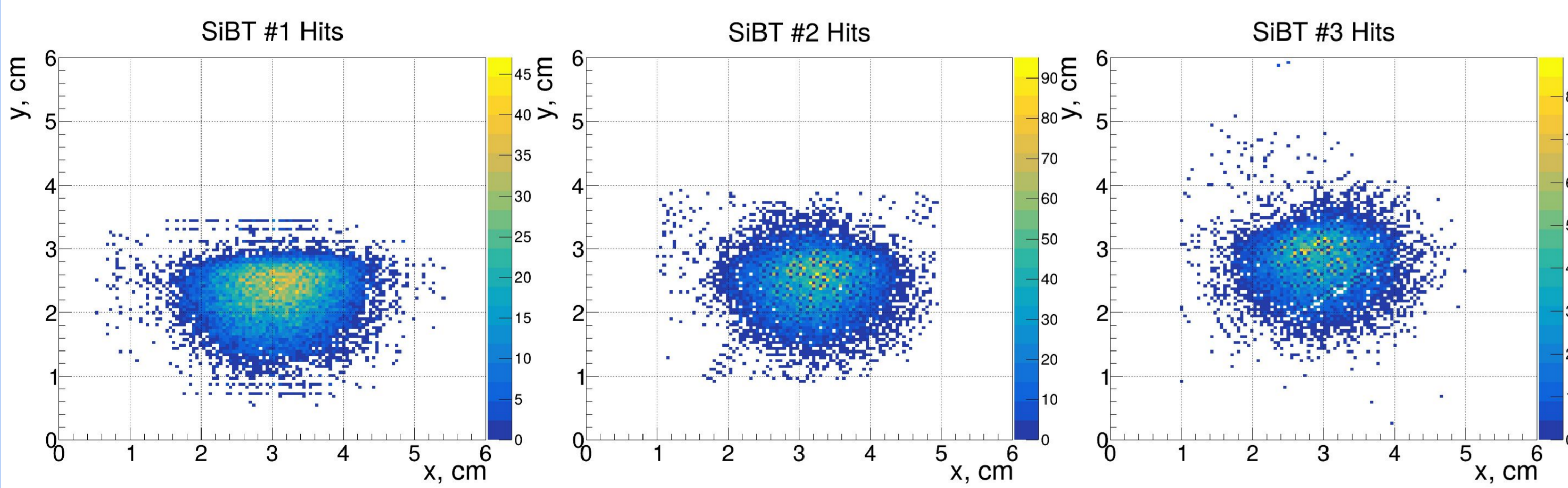

Tracking made by I. Rufanov (VBLHEP JINR)

Primary vertex residuals (inner tracker - SiBT)

Radiation damage

The SiBT's DSSDs were continuously irradiated by Xe ions. Radiation damage to silicon detectors increases the dark current, reduces charge collection efficiency (CCE), changes full depletion voltage, and increases the heat output at the detector. The estimates of SiBT radiation damage are presented below.

The dark current increment of the detectors depends linearly on the fluence³:

$$\Delta I = \alpha_I \cdot V \cdot \Phi_n$$

Based on the increments of the dark currents of individual strips, the spatial distribution of Xe ions passing through the detector was estimated.

$$N_{Xe(i,j)} = \frac{\Delta I_{i,j}}{\alpha \cdot V_{pix}} \cdot S \cdot \frac{1}{k}, \quad \Delta I_{i,j} = \Delta I_j \cdot \frac{I_i}{\sum I_i}$$

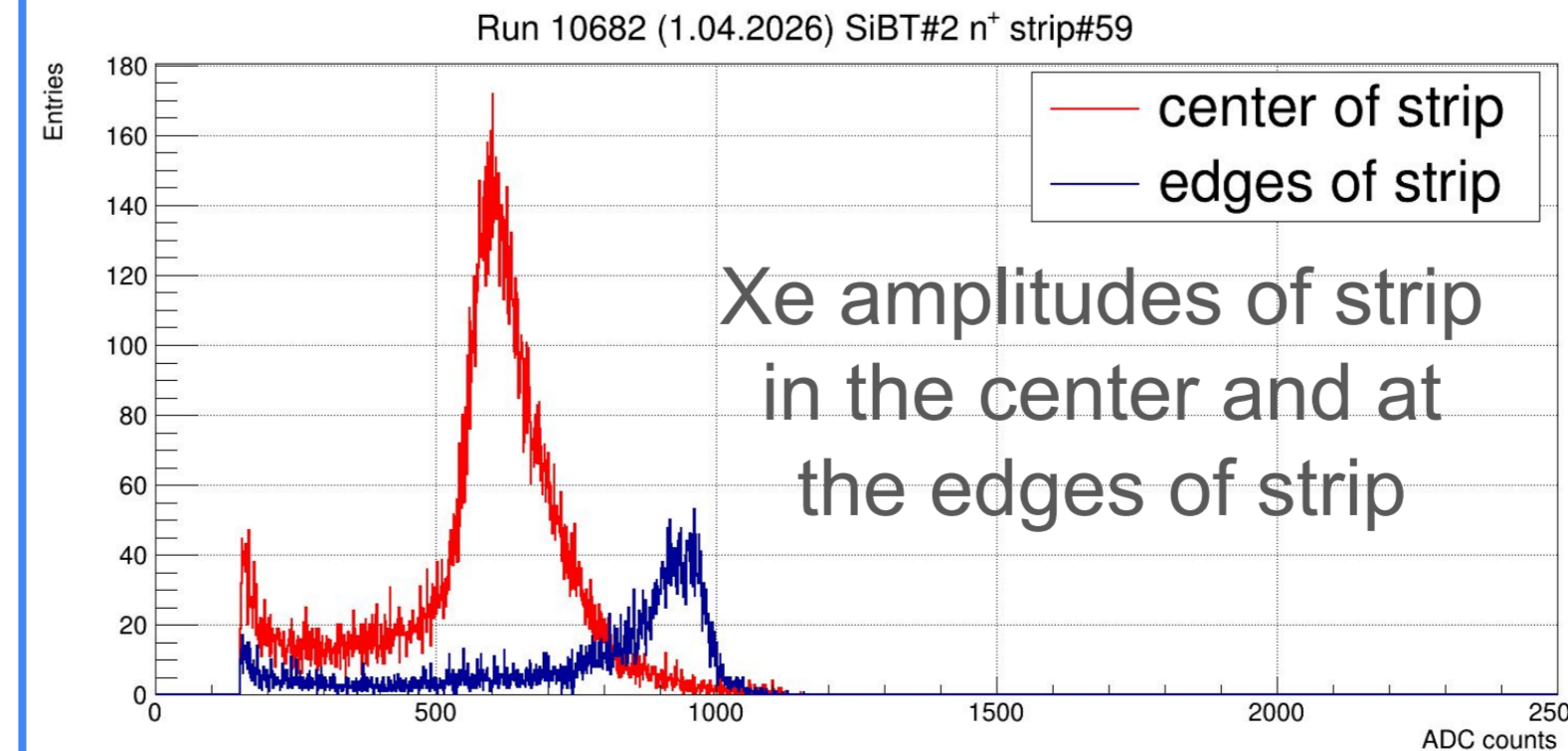
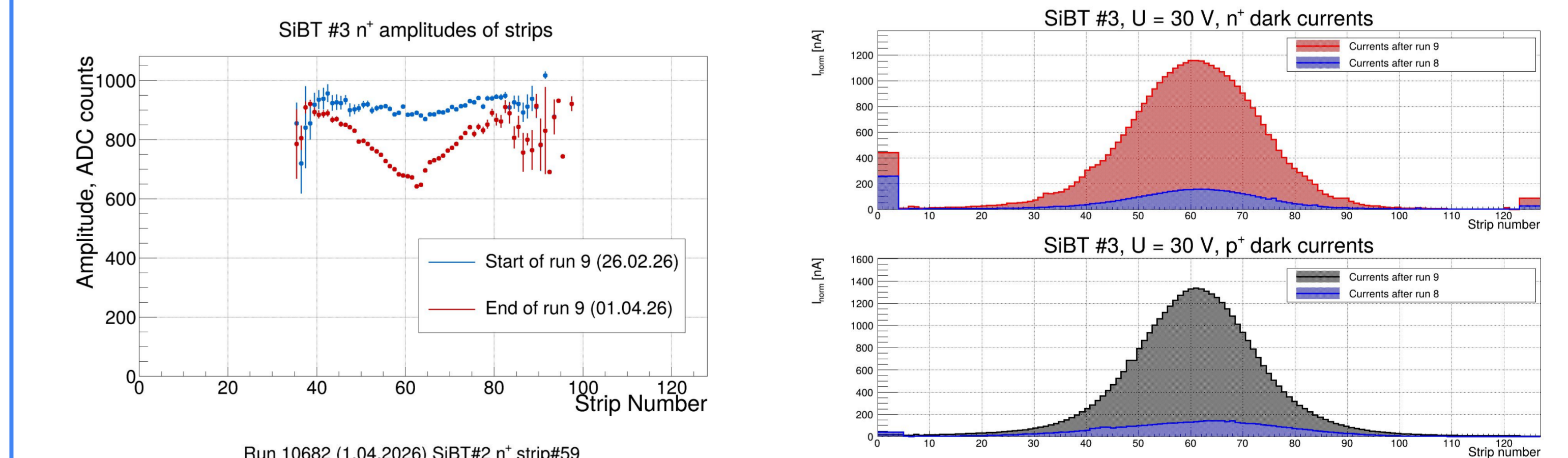
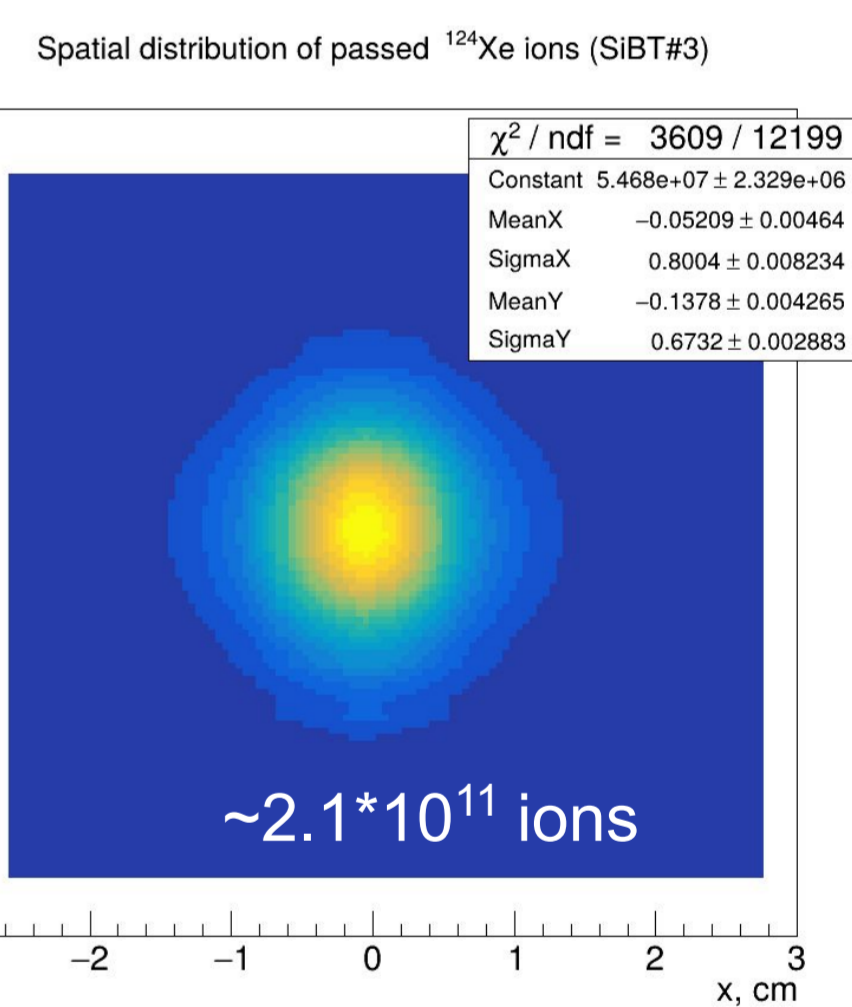

We conducted a test with an alpha source of one of the most damaged strips on the n+ side of the SiBT #3 detector. The alpha source was installed directly on the detector surface, and the signal amplitudes in the irradiated and non-irradiated areas of the strip were measured depending on the detector voltage

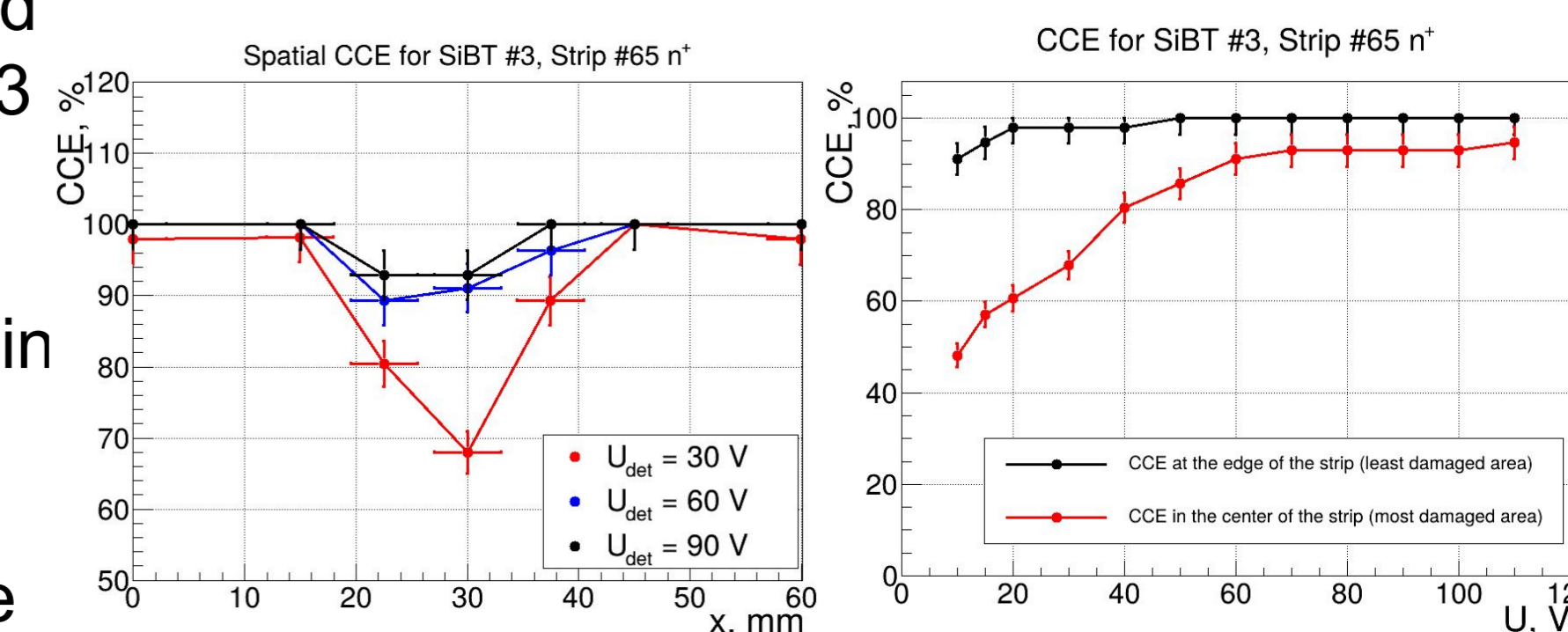
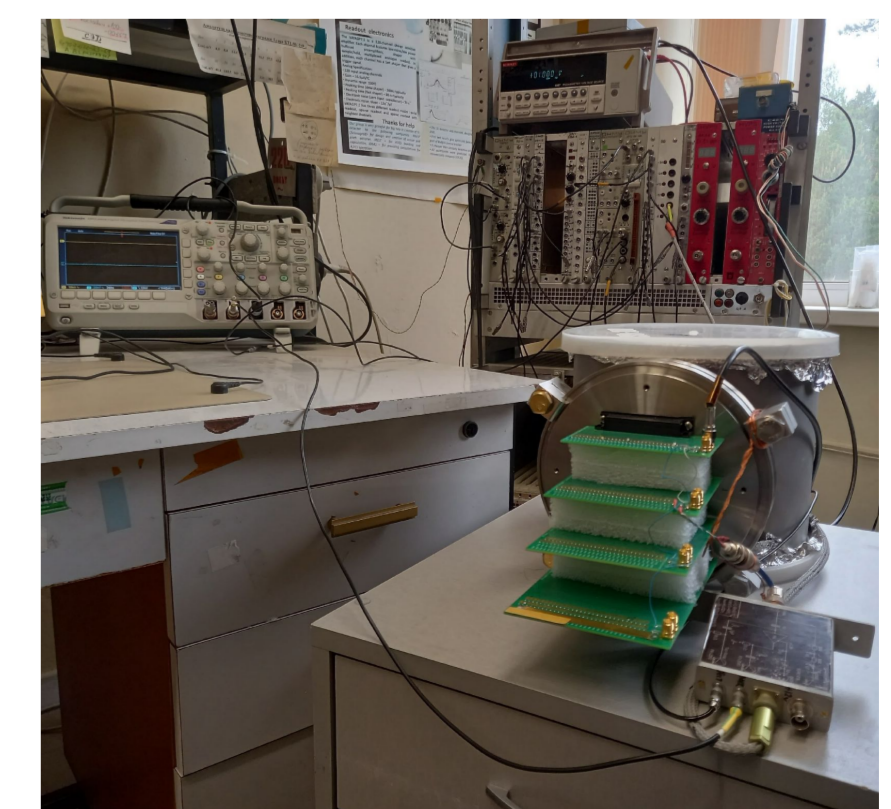

Conclusion

- The SiBT subsystem has been successfully integrated into the BM@N setup and has demonstrated stable operation during two experimental runs;
- The data obtained confirm the effectiveness of the system for reconstruction heavy ion tracks and monitoring beam parameters in real time;
- Unavoidable radiation damage can be used to determine the total ion flux during a run (can be used for applied tasks);
- The subsystem's performance in the next run will be ensured by increasing the detector bias voltage;
- The SiBT design provides for the possibility of modular replacement of sensors with new (non-irradiated) detectors.

References

1. "The BM@N spectrometer at the NICA accelerator complex". arXiv:2312.17573 [hep-ex]
2. IDEAS integrated circuits, <https://ideas.no/ideas-ic-products/>
3. Zamiatin N. I. et al., Method of measuring fast neutron fluence using planar silicon detectors//Physics of Particles and Nuclei Letters – 2017. – Vol. 14. – No. 5. – pp. 529-550.